

ZEAS Condensing Units

Refrigeration Condensing units

- » **Low & Medium temperature refrigeration**
- » **High energy efficiency**
- » **Low sound level**
- » **VRV® technology for refrigeration**



www.daikin.eu

LRMEQ5-20AY1(E)
LRLEQ5-20AY1(E)

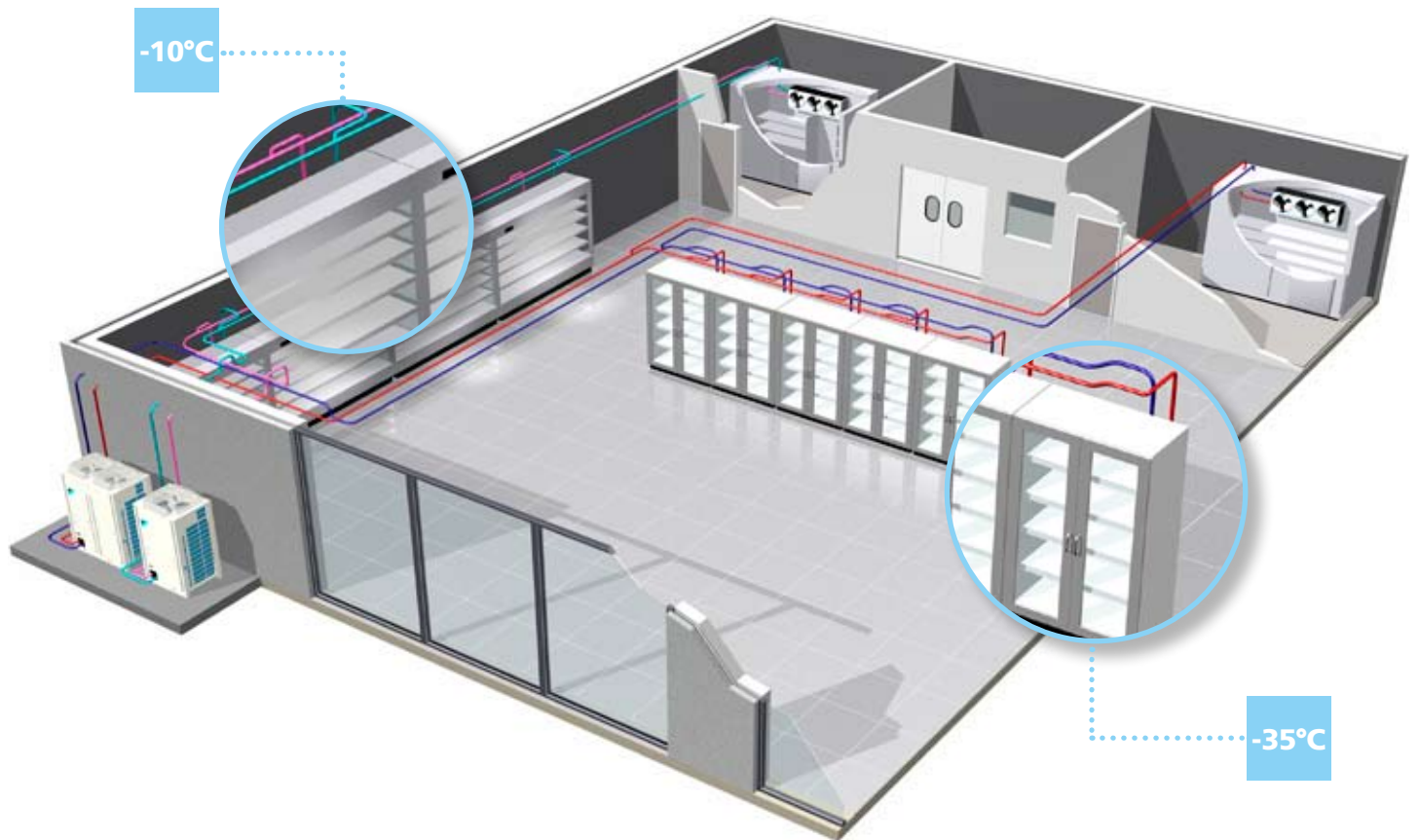

With this new range of inverter controlled condensing units Daikin expands its range of specific solutions for medium and low temperature refrigeration applications.

The ZEAS condensing units are the perfect solution for applications with fluctuating loads and high energy efficiency requirements such as supermarkets, blast coolers and freezers, cold storage, restaurants, petrol station shops, etc.

On top of that their reduced footprint and low sound functioning allow installation in virtually any available place.

MAIN BENEFITS

- > Small footprint
- > Fully equipped, easy to install solution
- > Low operating sound level
- > DC inverter scroll compressor with economiser function for high energy efficiency and reliable performance
- > VRV® (Variable Refrigerant Volume) technology for flexible application range

INSTALLER BENEFITS

- > Applicable for applications with variable load conditions
- > Factory tested and pre-programmed for quick and easy installation and commissioning
- > Increased installation flexibility thanks to limited dimensions
- > Parts and support available throughout the Daikin network

END-USER BENEFITS

- > Reduced CO₂ emissions thanks to the use of R-410A as a refrigerant and low energy consumption
- > Low sound level including 'night mode' operation
- > Strong anti-corrosion housing for long life, even in harsh environmental conditions
- > Fully packaged unit at a very competitive price

SCROLL COMPRESSOR WITH DC INVERTER TECHNOLOGY AND ECONOMIZER FUNCTION

- > The reluctance brushless DC motor provides significant increases in efficiency compared to conventional AC inverter motors, simultaneously using 2 different forms of torque (normal and reluctance torque) to produce extra power from small electric currents.
- > The motor comprises powerful neodymium magnets, that efficiently generate high torque. These magnets make a major contribution to the energy saving characteristics of the motor.
- > The unit is equipped with an economizer function. The refrigeration capacity to power consumption ratio improves significantly versus standard systems.

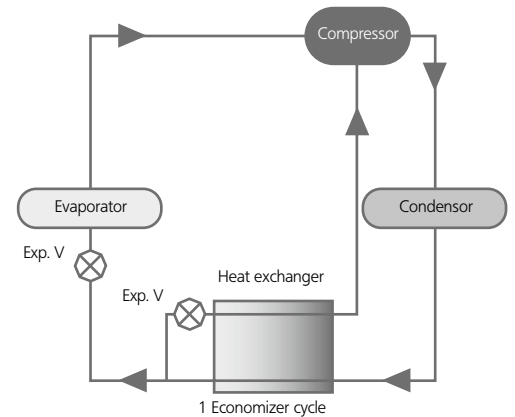

GOOD PART LOAD PERFORMANCE

Thanks to the characteristics of the DC inverter scroll compressor the performance and efficiency of the unit remains very high even in part load operation.

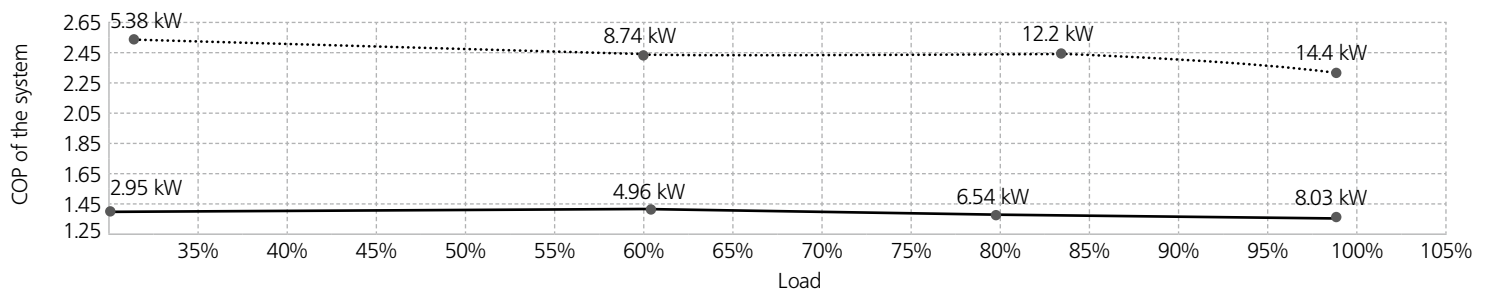

Medium temperature application:	Low temperature applications: —
$T_{\text{evaporation}} = 10^{\circ}\text{C}$	$T_{\text{evaporation}} = -30^{\circ}\text{C}$
Ambient temperature = 32°C	Ambient temperature = 32°C
Superheat = 10K	Superheat = 10K

R-410A REFRIGERANT

The ZEAS condensing units use R-410A as a refrigerant. R-410A has a lower global warming potential than R-404A and zero ozone depletion potential. Using R-410A allows usage of less refrigerant in the system and reduced piping sizes for an identical capacity.

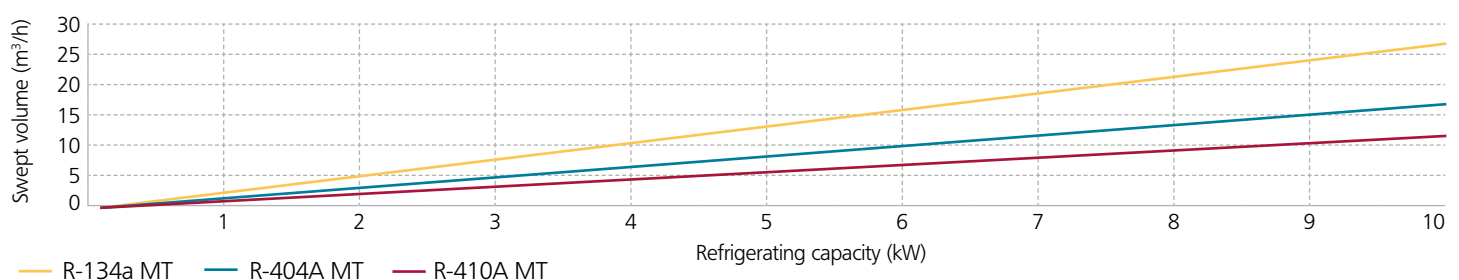



MEDIUM TEMPERATURE CAPACITY TABLE

Model name	Amb. Temp.	Saturated suction temperature													
		-20°C		-15°C		-10°C		-5°C		0°C		5°C		10°C	
		Q(kW)	P(kW)	Q(kW)	P(kW)	Q(kW)	P(kW)	Q(kW)	P(kW)	Q(kW)	P(kW)	Q(kW)	P(kW)	Q(kW)	P(kW)
LRMEQ5AY1(E)	20°C	10.4	3.66	11.8	3.69	13.5	3.72	14.4	3.76	15.7	3.80	17.0	3.84	18.3	3.97
	27°C	9.74	4.26	11.1	4.32	12.7	4.39	13.7	4.46	15.0	4.55	16.2	4.64	17.5	4.82
	32°C	9.24	4.85	10.6	4.93	12.2	5.00	13.1	5.12	14.4	5.26	15.6	5.39	16.9	5.60
	38°C	8.56	5.64	9.48	5.75	11.2	5.86	12.3	6.03	13.5	6.23	14.7	6.43	16.0	6.75
	43°C	7.82	6.37	9.06	6.57	10.4	6.79	11.4	7.19	12.7	7.44	13.8	7.62	15.0	7.84
LRMEQ6AY1(E)	20°C	12.7	4.49	14.4	4.51	16.1	4.54	17.7	4.60	19.3	4.63	20.9	4.72	22.6	4.79
	27°C	11.9	5.38	13.5	5.46	15.1	5.54	16.7	5.62	18.3	5.71	19.9	5.78	21.5	5.91
	32°C	11.2	6.05	12.8	6.17	14.4	6.30	16.0	6.44	17.6	6.60	19.2	6.75	20.7	6.99
	38°C	10.3	6.86	11.9	7.04	13.4	7.22	14.9	7.44	16.5	7.68	18.0	7.92	19.6	8.28
	43°C	9.36	7.33	10.8	7.62	12.3	7.93	13.8	8.38	14.7	8.39	15.1	8.08	15.1	7.72
LRMEQ8AY1(E)	20°C	16.3	5.91	18.5	5.96	20.7	6.00	22.9	6.08	25.0	6.12	27.1	6.17	29.3	6.23
	27°C	15.3	7.14	17.4	7.27	19.5	7.40	21.6	7.52	23.7	7.64	25.9	7.76	28.0	7.86
	32°C	14.4	8.10	16.5	8.29	18.6	8.50	20.7	8.70	22.8	8.92	24.8	9.15	26.9	9.39
	38°C	13.3	9.29	15.3	9.56	17.3	9.84	19.3	10.1	21.4	10.5	23.4	10.9	25.4	11.3
	43°C	12.0	10.6	14.0	10.9	15.9	11.4	17.9	12.1	19.9	12.6	21.9	13.0	23.8	13.2
LRMEQ10AY1(E)	20°C	19.1	7.07	21.8	7.12	24.3	7.18	26.9	7.26	29.4	7.30	32.0	7.33	34.5	7.38
	27°C	17.9	8.46	20.4	8.62	22.9	8.78	25.4	8.93	27.9	9.07	30.4	9.20	32.9	9.32
	32°C	16.9	9.52	19.3	9.75	21.8	10.0	24.3	10.3	26.7	10.5	29.2	10.79	31.7	11.1
	38°C	15.5	10.8	17.9	11.1	20.3	11.5	22.6	11.8	25.1	12.2	27.5	12.69	29.9	13.2
	43°C	14.0	11.8	16.3	12.4	18.6	12.8	20.9	13.7	23.3	14.4	25.6	14.8	26.7	14.4
LRMEQ12AY1(E)	20°C	21.4	8.01	24.4	8.09	27.3	8.15	30.1	8.26	33.0	8.31	35.8	8.36	38.7	8.41
	27°C	20.0	9.57	22.8	9.78	25.7	9.96	28.5	10.1	31.3	10.3	34.1	10.8	36.9	10.6
	32°C	18.8	10.7	21.6	11.0	24.4	11.3	27.2	11.6	29.9	11.9	32.7	12.7	35.5	12.5
	38°C	17.3	12.1	20.0	12.5	22.7	12.9	25.3	13.3	28.1	13.8	30.8	14.3	33.5	14.8
	43°C	15.6	13.0	18.2	13.6	20.8	14.2	23.2	14.9	24.9	14.9	26.9	14.9	28.1	14.5
LRMEQ15AY1(E)	20°C	28.1	10.2	32.0	10.3	36.0	10.4	39.8	10.5	43.7	10.6	47.6	10.7	51.4	10.9
	27°C	26.2	12.3	30.0	12.5	33.9	12.7	37.6	13.0	41.4	13.2	45.3	13.4	49.1	13.6
	32°C	24.7	13.8	28.5	14.1	32.2	14.5	35.9	14.9	39.7	15.3	43.4	15.7	47.2	16.2
	38°C	22.7	15.6	26.3	16.1	29.9	16.6	33.5	17.2	37.2	17.8	40.8	18.5	44.5	19.3
	43°C	20.5	17.1	23.9	17.9	27.4	18.8	31.0	19.9	34.5	20.9	38.0	21.4	38.8	20.4
LRMEQ20AY1(E)	20°C	32.3	11.6	36.9	11.9	41.4	12.0	45.8	12.2	50.3	12.2	54.8	12.3	59.3	12.5
	27°C	30.1	13.9	34.5	14.4	38.9	14.6	43.3	14.9	47.7	15.1	52.1	15.4	56.5	15.7
	32°C	28.4	15.8	32.7	16.2	37.0	16.6	41.3	17.0	45.7	17.5	50.0	17.9	54.4	18.5
	38°C	26.0	17.5	30.2	18.4	34.3	18.9	38.5	19.6	42.8	20.2	47.0	21.0	50.2	21.4
	43°C	23.5	19.1	27.5	19.9	31.5	20.9	34.5	21.4	37.1	21.4	38.1	20.3	38.1	19.1

Q: Cooling capacity
P: Power consumption
Performance data based on a superheat = 10 K and liquid subcooling inherent the system

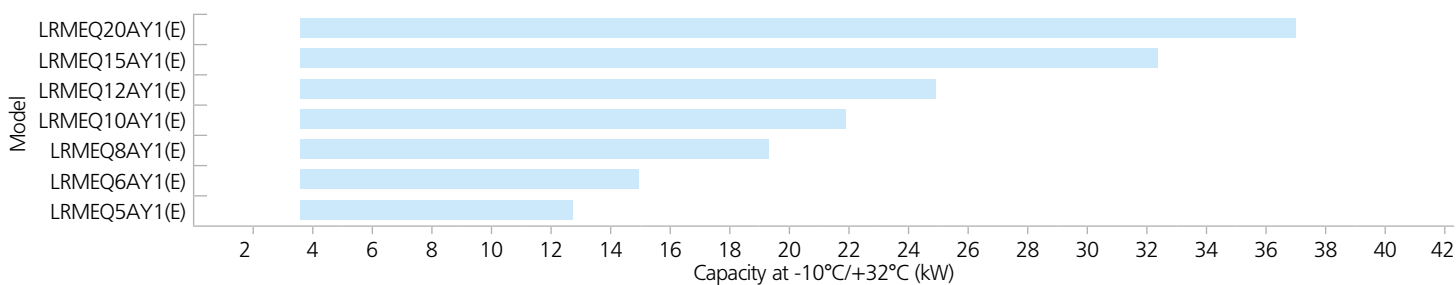

LOW TEMPERATURE CAPACITY TABLE

Model name	Amb. Temp.	Saturated suction temperature											
		-45°C		-40°C		-35°C		-30°C		-25°C		-20°C	
		Q(kW)	P(kW)	Q(kW)	P(kW)	Q(kW)	P(kW)	Q(kW)	P(kW)	Q(kW)	P(kW)	Q(kW)	P(kW)
LRLEQ5AY1(E)	20°C	2.67	3.24	4.74	3.39	6.18	3.50	7.46	3.57	8.96	3.63	10.4	3.66
	27°C	2.53	3.80	4.43	3.92	5.74	4.05	6.94	4.12	8.37	4.20	9.74	4.26
	32°C	2.42	4.33	4.18	4.46	5.40	4.60	6.54	4.67	7.91	4.75	9.24	4.85
	38°C	2.25	5.20	3.82	5.34	4.91	5.49	5.96	5.58	7.06	5.57	8.56	5.64
	43°C	2.08	5.63	3.49	5.76	4.48	5.93	5.51	6.06	6.46	6.21	7.82	6.37
LRLEQ6AY1(E)	20°C	3.36	4.23	5.89	4.33	7.34	4.40	9.30	4.43	11.1	4.45	12.7	4.49
	27°C	3.14	4.88	5.44	5.03	6.76	5.13	8.59	5.20	10.3	5.28	11.9	5.38
	32°C	2.96	5.39	5.08	5.57	6.30	5.70	8.03	5.79	9.70	5.90	11.2	6.05
	38°C	2.68	6.18	4.53	6.40	5.62	6.56	7.22	6.69	8.55	6.71	10.3	6.86
	43°C	2.43	6.53	4.08	6.75	5.06	6.93	6.59	7.14	7.76	7.23	9.36	7.33
LRLEQ8AY1(E)	20°C	4.27	5.42	7.46	5.56	9.24	5.72	11.7	5.79	14.1	5.86	16.3	5.91
	27°C	4.01	6.38	6.92	6.56	8.55	6.77	10.9	6.90	13.1	7.03	15.3	7.14
	32°C	3.80	7.15	6.49	7.35	8.00	7.60	10.2	7.76	12.4	7.93	14.4	8.10
	38°C	3.48	8.35	5.85	8.59	7.19	8.88	9.23	9.09	11.0	9.14	13.3	9.29
	43°C	3.17	9.04	5.27	9.29	6.48	9.61	8.44	9.91	9.95	10.3	12.0	10.6
LRLEQ10AY1(E)	20°C	5.01	6.54	8.87	6.71	11.0	6.88	14.0	6.96	16.8	7.03	19.1	7.07
	27°C	4.69	7.54	8.19	7.78	10.1	8.03	12.9	8.18	15.6	8.34	17.9	8.46
	32°C	4.41	8.31	7.64	8.59	9.40	8.90	12.1	9.10	14.7	9.32	16.9	9.52
	38°C	3.99	9.49	6.81	9.84	8.39	10.2	10.9	10.5	12.9	10.6	15.5	10.8
	43°C	3.61	10.0	6.12	10.4	7.54	10.8	9.91	11.2	11.7	11.4	14.0	11.8
LRLEQ12AY1(E)	20°C	5.46	7.25	9.73	7.46	12.1	7.59	15.4	7.72	18.5	7.85	21.4	8.01
	27°C	5.08	8.28	8.95	8.58	11.1	8.80	14.2	8.97	17.2	9.18	20.0	9.57
	32°C	4.76	9.07	8.32	9.42	10.3	9.70	13.2	9.93	16.1	10.2	18.8	10.7
	38°C	4.28	10.3	7.37	10.7	9.14	11.1	11.9	11.4	14.2	11.6	17.3	12.1
	43°C	3.85	10.8	6.59	11.2	8.18	11.6	10.8	12.1	12.8	12.5	15.6	13.0
LRLEQ15AY1(E)	20°C	6.94	9.37	12.7	9.61	15.9	9.84	20.4	9.97	24.7	10.1	28.1	10.2
	27°C	6.47	10.8	11.7	11.1	14.6	11.5	18.9	11.7	22.9	12.0	26.2	12.3
	32°C	6.09	11.9	10.9	12.3	13.6	12.7	17.6	13.0	21.5	13.3	24.7	13.8
	38°C	5.50	13.6	9.69	14.0	12.1	14.6	15.8	15.0	18.9	15.1	22.7	15.6
	43°C	4.97	14.3	8.69	14.8	10.9	15.4	14.4	16.0	17.2	16.4	20.5	17.1
LRLEQ20AY1(E)	20°C	7.63	10.4	14.1	10.7	17.7	10.9	22.8	11.0	27.6	11.3	32.3	11.6
	27°C	7.09	11.9	12.9	12.3	16.3	12.6	21.0	12.9	25.6	13.3	30.1	13.9
	32°C	6.65	13.0	12.0	13.4	15.1	13.9	19.6	14.3	24.0	14.6	28.4	15.8
	38°C	5.96	14.7	10.6	15.2	13.4	15.8	17.5	16.3	21.1	16.8	26.0	17.5
	43°C	5.36	15.4	9.48	16.0	12.0	16.6	15.9	17.3	19.0	18.0	23.5	19.1

Q: Cooling capacity

P: Power consumption

Performance data based on a superheat = 10 K and liquid subcooling inherent the system

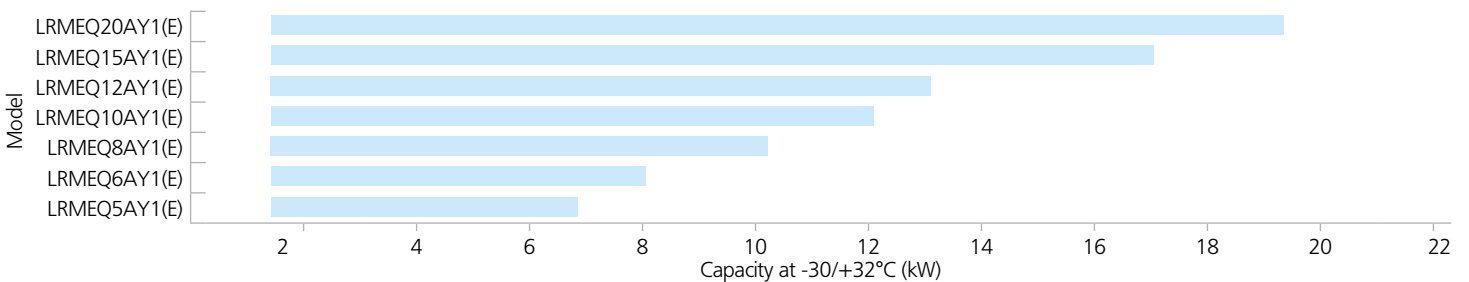

TECHNICAL AND ELECTRICAL SPECIFICATIONS

MEDIUM TEMPERATURE SERIES

Model (1)			LRMEQ5AY1(E)	LRMEQ6AY1(E)	LRMEQ8AY1(E)	LRMEQ10AY1(E)	LRMEQ12AY1(E)	LRMEQ15AY1(E)	LRMEQ20AY1(E)	
Power supply			3 phase / 50Hz / 380-415V							
Capacity (2)		kW	12.2	14.4	18.6	21.8	24.4	32.2	37.0	
Range of Suction pressure equivalent saturation temperature			-20 ~ +10							
Range of outdoor temperature			-15 ~ +43							
Dimensions		Height x Width x Depth	1,680 × 635 × 765		1,680 × 930 × 765			1,680 × 1,240 × 765		
Heat exchanger			Cross fin coil							
Compressor	N° of compressors		1	1	2	2	2	3	3	
	Type		Hermetically sealed scroll type							
	Swept volume		m³/h	10.04	13.85	19.68	23.36	25.27	30.00	35.80
	Number of revolutions		r.p.m	4,740	6,540	4,320.29	6,060.29	6,960.29	5,640.29	6,960.29
	Motor output × number of compressors		kW	2.3	3.2	2.1+3.6	3.0+3.6	3.4+3.6	2.8+3.6+3.6	3.4+3.6+3.6
Starting method			Direct-on-line(Inverter system)							
Fan	Type		Propeller fan							
	Motor output		kW	0.35×1		0.75×1			0.75×2	
	Air flow rate		m³/min	95	102	171	179	191	230	240
	Drive		Direct drive							
Connecting pipes	Liquid pipe		Ø 9.5 C1220T (Brazeing connection)		Ø 9.5 C1220T (Brazeing connection)			Ø 12.7 C1220T (Brazeing connection)		
	Gas pipe		Ø 19.1 C1220T (Brazeing connection)		Ø 25.4 C1220T (Brazeing connection)			Ø 31.8 C1220T (Brazeing connection)		
Receiver volume		l	5.4		8.1			12.1		
Mass			175		255			355		
Refrigerant	Type		R-410A		R-410A			R-410A		
	Charge volume		kg	5.2		7.9			11.5	
Refrigerant oil	Refrigerant oil name		DAPHNE FVC68D		DAPHNE FVC68D			DAPHNE FVC68D		
	Charge volume		l	1.7+2.5		1.7+2.1+3.0			1.7+2.1+2.1+4.0	
Sound pressure (3)	at 1m		dBA	55	56	57	59	61	62	63
	at 10m		dBA	34	36	37	39	41	42	43
Unit	Maximum starting current (380V/400V/415V)		A	-	-	78 / 74 / 72	79 / 75 / 73	79 / 75 / 73	89 / 84 / 81	89 / 84 / 81
	Nominal running current (380V/400V/415V)		A	7.5 / 7.0 / 6.8	9.4 / 8.9 / 8.6	12.7 / 12.0 / 11.8	15.2 / 14.4 / 14.0	18.1 / 17.2 / 16.7	37.7 / 21.6 / 20.8	27.3 / 25.8 / 25.0

(1) shows the salt damage-proof specification machine.

(2) Rated conditions of the refrigeration equipment : Saturated temperature equivalent to suction pressure : -10°C, Outdoor air: 32°C, Suction SH: 10°C

(3) Measurement place: Front: 1m, Height: 1.5m according to EN13900

LOW TEMPERATURE SERIES

Model (1)			LRLEQ5AY1(E)	LRLEQ6AY1(E)	LRLEQ8AY1(E)	LRLEQ10AY1(E)	LRLEQ12AY1(E)	LRLEQ15AY1(E)	LRLEQ20AY1(E)	
Power supply			3 phase / 50Hz / 380-415V							
Capacity (2)		kW	5.4	6.3	8.0	9.4	10.3	13.6	15.1	
Range of Suction pressure equivalent saturation temperature			-45 ~ -20							
Range of outdoor temperature			-15 ~ +43							
Dimensions		Height x Width x Depth	1,680 × 635 × 765		1,680 × 930 × 765			1,680 × 1,240 × 765		
Heat exchanger			Cross fin coil							
Compressor	N° of compressors		1	1	2	2	2	3	3	
	Type		Hermetically sealed scroll type							
	Swept volume		m³/h	10.04	13.85	19.68	23.36	25.27	30.00	35.80
	Number of revolutions		r.p.m	4,740	6,540	4,320.29	6,060.29	6,960.29	5,640.29	6,960.29
	Motor output × number of compressors		kW	2.3	3.2	2.1+3.6	3.0+3.6	3.4+3.6	2.8+3.6+3.6	3.4+3.6+3.6
Starting method			Direct-on-line(Inverter system)							
Fan	Type		Propeller fan							
	Motor output		kW	0.35×1		0.75×1			0.75×2	
	Air flow rate		m³/min	95	102	171	179	191	230	240
	Drive		Direct drive							
Connecting pipes	Liquid pipe		Ø 9.5 C1220T (Brazeing connection)		Ø 9.5 C1220T (Brazeing connection)			Ø 12.7 C1220T (Brazeing connection)		
	Gas pipe		Ø 19.1 C1220T (Brazeing connection)		Ø 25.4 C1220T (Brazeing connection)			Ø 31.8 C1220T (Brazeing connection)		
Receiver volume		l	5.4		8.1			12.1		
Mass			175		255			355		
Refrigerant	Type		R410A							
	Charge volume		kg	5.2		7.9			11.5	
Refrigerant oil	Refrigerant oil name		DAPHNE FVC68D							
	Charge volume		l	1.7+2.5		1.7+2.1+3.0			1.7+2.1+2.1+4.0	
Sound pressure (3)	at 1m		dBA	55	56	57	59	61	62	63
	at 10m		dBA	34	36	37	39	41	42	43
Unit	Maximum starting current (380V/400V/415V)		A	-	-	78 / 74 / 72	79 / 75 / 73	79 / 75 / 73	89 / 84 / 81	89 / 84 / 81
	Nominal running current (380V/400V/415V)		A	6.7 / 6.4 / 6.2	8.4 / 8.0 / 7.7	11.3 / 10.7 / 10.4	14.0 / 13.3 / 12.9	14.7 / 14.0 / 13.6	19.7 / 18.6 / 17.9	21.5 / 20.4 / 19.6

(1) shows the salt damage-proof specification machine.

(2) Rated conditions of the refrigeration equipment : Saturated temperature equivalent to suction pressure : -35°C, Outdoor air: 32°C, Suction SH: 10°C

(3) Measurement place: Front: 1m, Height: 1.5m according to EN13900

DIMENSIONS

LRMEQ5-6AY1(E), LRLEQ5-6AY1(E)

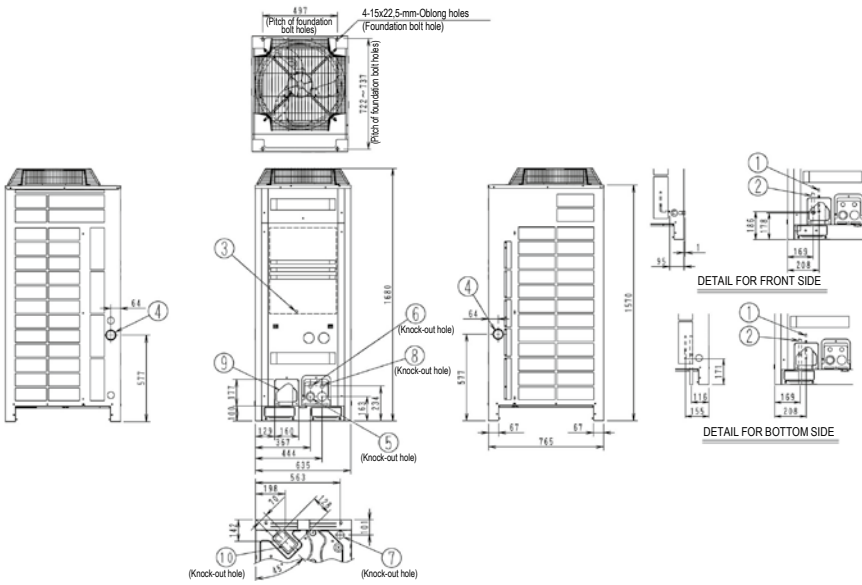

No.	Parts name	Remarks
1	Liquid pipe connection port	Ø 9.5
2	Gas pipe connection port	Ø 19.1
3	Grounding terminal	Inside of switch box (M8)
4	Power cord routing hole (side)	Ø 62
5	Power cord routing hole (front)	Ø 45
6	Power cord routing hole (front)	Ø 27
7	Power cord routing hole (bottom)	Ø 50
8	Wire routing hole (front)	Ø 27
9	Pipe routing hole (front)	
10	Pipe routing hole (bottom)	

LRMEQ8-10-12AY1(E), LRLEQ8-10-12AY1(E)

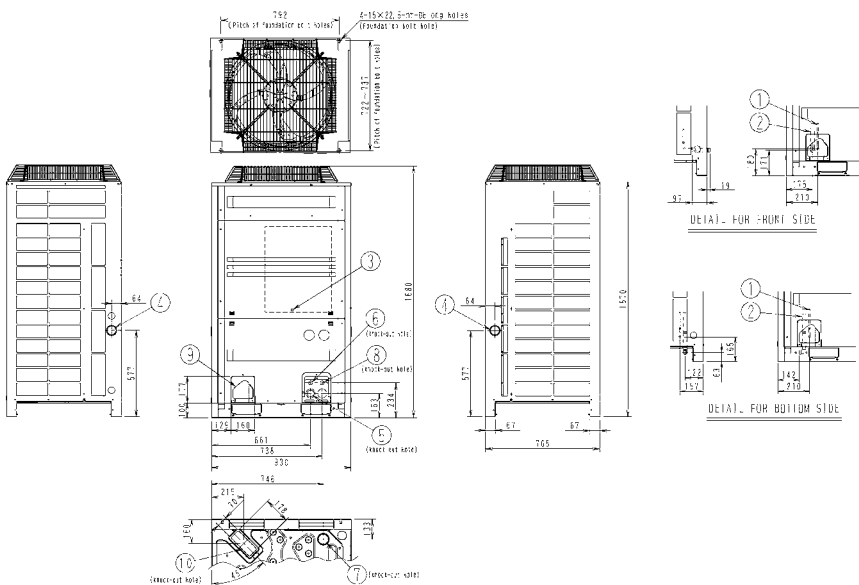

No.	Parts name	Remarks
1	Liquid pipe connection port	Ø 9.5
2	Gas pipe connection port	Ø 25.4
3	Grounding terminal	Inside of switch box (M8)
4	Power cord routing hole (side)	Ø 62
5	Power cord routing hole (front)	Ø 45
6	Power cord routing hole (front)	Ø 27
7	Power cord routing hole (bottom)	Ø 65.5
8	Wire routing hole (front)	Ø 27
9	Pipe routing hole (front)	
10	Pipe routing hole (bottom)	

Notes:
Detail for front side and detail for bottom side indicate the dimensions after fixing the attached piping.

LRMEQ15-20AY1(E), LRLEQ15-20AY1(E)

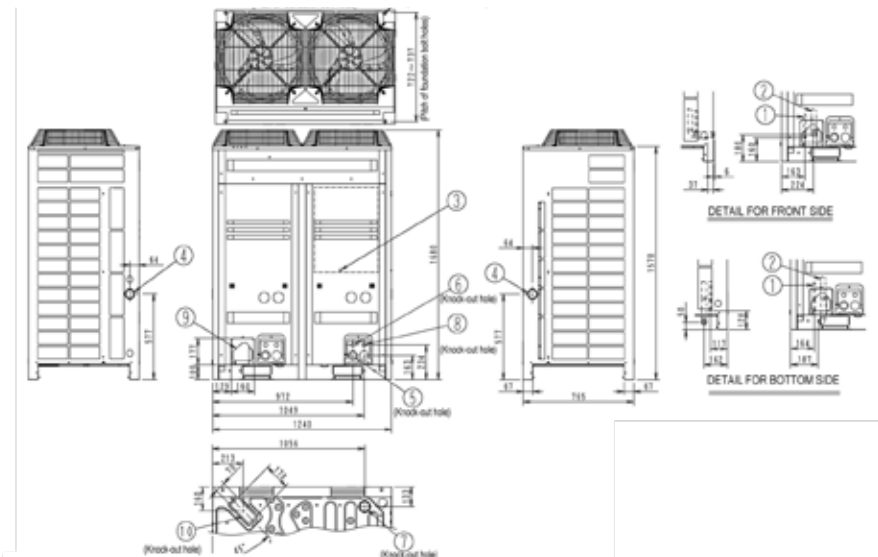

No.	Parts name	Remarks
1	Liquid pipe connection port	Ø 12.7
2	Gas pipe connection port	Ø 31.8
3	Grounding terminal	Inside of switch box (M8)
4	Power cord routing hole (side)	Ø 62
5	Power cord routing hole (front)	Ø 45
6	Power cord routing hole (front)	Ø 27
7	Power cord routing hole (bottom)	Ø 65.5
8	Wire routing hole (front)	Ø 27
9	Pipe routing hole (front)	
10	Pipe routing hole (bottom)	

Notes:
Detail for front side and detail for bottom side indicate the dimensions after fixing the attached piping.

DAIKIN OFFERS A WIDE RANGE OF REFRIGERATION UNITS FOR COMMERCIAL, PROFESSIONAL AND INDUSTRIAL APPLICATIONS. DAIKIN REFRIGERATION UNITS COMBINE EFFICIENCY AND RELIABILITY WITH EASY INSTALLATION AND MAINTENANCE.



ZEAS CONDENSING UNITS



CONDENSING UNITS FOR HIGH CAPACITIES



CONVENI-PACK



Daikin's unique position as a manufacturer of air conditioning equipment, compressors and refrigerants has led to its close involvement in environmental issues.

For several years Daikin has had the intention to become a leader in the provision of products that have limited impact on the environment.

This challenge demands the eco design and development of a wide range of products and an energy management system, resulting in energy conservation and a reduction of waste.



Daikin Europe N.V. is approved by LRQA for its Quality Management System in accordance with the ISO9001 standard. ISO9001 pertains to quality assurance regarding design, development, manufacturing as well as to services related to the product.



ISO14001 assures an effective environmental management system in order to help protect human health and the environment from the potential impact of our activities, products and services and to assist in maintaining and improving the quality of the environment.



Daikin units comply with the European regulations that guarantee the safety of the product.

The present leaflet is drawn up by way of information only and does not constitute an offer binding upon Daikin Europe N.V.. Daikin Europe N.V. has compiled the content of this leaflet to the best of its knowledge. No express or implied warranty is given for the completeness, accuracy, reliability or fitness for particular purpose of its content and the products and services presented therein. Specifications are subject to change without prior notice. Daikin Europe N.V. explicitly rejects any liability for any direct or indirect damage, in the broadest sense, arising from or related to the use and/or interpretation of this leaflet. All content is copyrighted by Daikin Europe N.V.

DAIKIN EUROPE N.V.

Naamloze Vennootschap
Zandvoordestraat 300
B-8400 Oostende, Belgium
www.daikin.eu
BE 0412 120 336
RPR Oostende

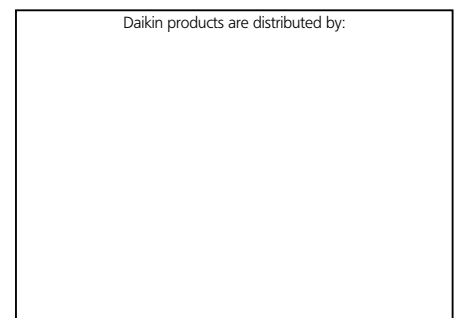

ECPEN09-741 • XX • 08/09 • Copyright: Daikin
Printed on non-chlorinated paper. Prepared by La Movida, Belgium. 
Responsible Editor: Daikin Europe N.V., Zandvoordestraat 300, B-8400 Oostende